

Tiger Super Automatic Espresso Machine

ITEM#

PROJECT

DATE



Model Tiger M Series

Dimensions: 23.8"H x 15.8"W x 18.1"D
(60.5 cm H x 40.1 cm W x 45.9 cm D)

Features

BUNN Espresso® Tiger M Series

Simple solution for exceptional espresso beverages from a sleek, compact super-automatic

- Up to 180 shots per hour from less than 16" of counter space.
- Intelligent modular brewing chamber adjusts espresso.
- Simulates barista tamping and polishing motion to provide uniform extraction.
- One (M-1) or two-grinder (M-2) models available for regular and decaf or other specialty beans.
- Hoppers hold 3 lbs (M-1) or 1.75 lbs (M-2) of fresh beans.
- Adjusts for 3 to 5.7 inch cup clearance.
- Pod brewing option standard on all models.
- Intuitive operational design. Easy-to-use control pad guides user through steps for making drinks.
- Easy daily cleaning.
- Innovative milk delivery system does not inject steam or water to dilute the foam so customers enjoy a full, rich flavor experience.
- Internal milk storage. Self-contained chiller system holds 1 gallon of your choice of milk.

For current specification sheets and other information, go to www.bunn.com.

Related Products

Espresso Water Quality System

EQHP-ESP
Product No.: 39000.0008



Replacement Cartridge

EQHP-ESPCRTG
Product No.: 39000.1008

Booster Pump Kit

w/.357 hoses
Product No.: 41815.1000



Cafiza™ Cleaning Tablets

Product No.: 36000.1189 (100 count)
Product No.: 36000.1188 (12/case)



Rinza™

Milk Frother Cleaner
Product No.: 39265.0000 (each)
Product No.: 39265.0001 (6/case)



Cup Heater

Product No.: 35800.0400



Steamer

Product No.: 35800.0401



Model

Agency Listing

Tiger M-1



Tiger M-2



Dimensions & Specifications

Model	Product #	Volts	Amps	Tank Heater Watts	Total Watts	Capacity	Cubic Measure	Shipping Weight	Cord Attached
Tiger M-1*	35800.0000	120	16	1700	1850	180 shots/hr	12.5 ft ³	86 lbs	Yes/20A Plug
Tiger M-1*	35800.0001	208	12	2000	2400	180 shots/hr	12.5 ft ³ (.35 m ³)	86 lbs (39 kg)	Yes/No Plug
Tiger M-2**	35800.0002	120	16	1700	1850	180 shots/hr	12.5 ft ³	88 lbs	Yes/20A Plug
Tiger M-2**	35800.0003	208	12	2000	2400	180 shots/hr	12.5ft ³ (.35 m ³)	88 lbs (39.9 kg)	Yes//No Plug

Capacity per Hour: Espresso: 180 Cappuccino: 120
 Latte: 100 POD Products: 60
 Hot Water: 7.9 gallons (30 litres)

*Single hopper and grinder. **Model with two hoppers and grinders.

Model includes: Machine, water filtration system, installation and 2-year preventive maintenance.

Electrical: Model requires 2-wire grounded service rated 120/208V, single phase, 50/60 Hz.

Plumbing: 20-100 psi (138 - 690 kPa). Machine supplied with 1/4" male flare fitting.

Booster pump is required for Tiger Steam. It can be utilized for all M Series and Cool Froth models in locations with inconsistent water pressure or where bottled water is used.

Drain: All machines are supplied with a waste water hose and must be connected to a drain.

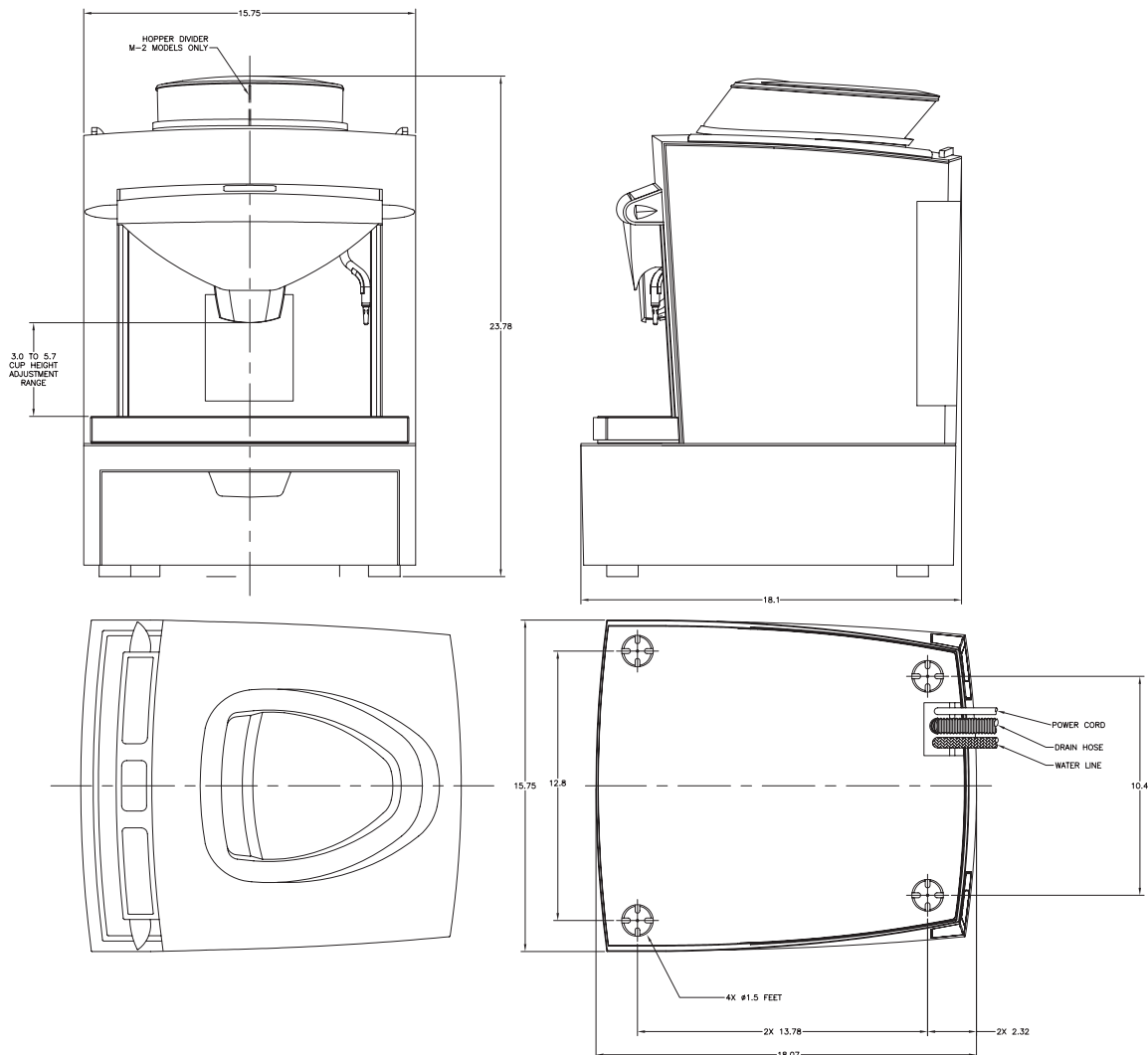

Bunn-O-Matic® Corporation - 1400 Stevenson Drive Springfield, Illinois 62703 • 800-637-8606 • 217-529-6601 • Fax 217-529-6644 • www.bunn.com

BUNN® practices continuous product research and improvement. We reserve the right to change specifications and product design without notice. Such revisions do not entitle the buyer to corresponding changes, improvements, additions or replacements for previously purchased equipment.

All dimensions shown in inches.