

BrewWISE® Single Soft Heat® DBC® Brewer

ITEM#

PROJECT

DATE

Features

BrewWISE Brewing System

- Brews 11.4 gallons (43.2 litres) of perfect coffee per hour.
- Brews ½, 1, or 1½ gallon (1.9, 3.8 or 5.7 litre) batches.
- Stores individual coffee and flavor profiles using adjustable water volume, bypass percentage, pulse brew, and pre-infusion timing.
- Operate any combination of BrewWISE equipment error-free with wireless brewer-grinder interface via Smart Funnel®.
- Reduce accidents with safety features that decrease hot splashes from funnel, eliminate brewing when funnel or server is not present.
- Troubleshoot all switches and electrical components from the front panel with advanced diagnostic service tools.
- Consistently brew perfect coffee using Digital Brewer Control with pulse brew.
- Simplify installation and calibration by creating your own recipe cards and dedicated funnels with the BrewWISE Recipe Writer using your PC (Windows® compatible).
- International electrical configurations available.



Model Single SH DBC with 1.5 gallon SH Servers

(servers sold separately)

Dimensions: 35.8" H x 9.3" W x 21.2" D
(90.9cm H x 23.6cm W x 53.8cm D)

For current specification sheets and other information, go to www.bunn.com.

Related Products

Easy Clear® EQHP-10
Product No. : 39000.0004



Easy Clear® EQHP-10L
Product No. : 39000.0001

Single/Dual Filter Pack
Product No. : 20138.0000
Packed per case: 500
Dimensions:
5¼" Base x 4¼" Sidewall
13.3 cm Base x 10.8 cm Sidewall



BrewWISE® Recipe Writer (BRW)
Product No.: 34444.0000 (120V)
Dimensions:
2¾" H x 6⅞" W x 9½" D
5.56 cm H x 16.2 cm W x 24.1 cm D



Recipe Card
Product No.: 34447.0000
• Program a recipe to be used on brewer or grinder.



Ad Card
Product No.: 34448.0000
• Program a message to appear on the brewer's display.

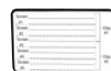

G9-2T DBC
Product No.: 33700.0000
G9-2TA DBC
Intl. Product No.: 33700.0005
• Grinder holds 6 pounds each of regular and decaf or specialty beans.



Model

Single SH DBC
G9-2T DBC
SH Server and Stands

Agency Listing



Dimensions & Specifications

Model	Product #	Volts	Amps	Tank Heater Watts	Total Watts	Capacity	Cubic Measure	Shipping Weight	Cord Attached
Single SH DBC	33600.0000	120/240	17.5	4000	4100	11.4 gal./hr.	7.9 ft ³	59 lbs.	No
Single SH DBC [†]	33600.0001	120/240	17.5	4000	4100	11.4 gal./hr.	7.9 ft ³	59 lbs.	No
Single SH DBC	33600.0013	120/240	17.5	4000	4100	11.4 gal./hr.	7.9 ft ³	59 lbs.	No
G9-2T DBC	33700.0000	120	9.4	n/a	1128	n/a	5.9 ft ³	67 lbs.	Yes
SH Server (1.5 gal.)	27850.0001	n/a	n/a	n/a	n/a	1.9 gal.	2.4 ft ³	17 lbs.	n/a
SH Server* (1.5 gal.)	27850.0004	n/a	n/a	n/a	n/a	1.9 gal.	2.4 ft ³	17 lbs.	n/a
1SH Stand	27825.0000	120	.8	n/a	90	1 SH Server	1.2 ft ³	13 lbs.	Yes
1SH Stand*	27825.0004	120	.8	n/a	90	1 SH Server	1.2 ft ³	13 lbs.	Yes
2SH Stand	27875.0000	120	1.5	n/a	180	2 SH Servers	2.1 ft ³	22 lbs.	Yes
2SH Stand*	27875.0003	120	1.5	n/a	180	2 SH Servers	2.1 ft ³	22 lbs.	Yes

*Models have black decor. [†]Model has funnel lock system. Note: Soft Heat® Brewers and Servers are boxed and shipped separately.

Brewing capacity: based upon incoming water temp of 60°F (140°F rise).

Models listed as 120/208V or 120/240V must be connected to 208V or 240V electrical service respectively. Please refer to the installation manual.

Electrical: Brewer is 3-wires plus ground service rated 120/240V, single phase, 60Hz.

Grinder is 2-wires plus ground service rated 120V, 60Hz, circuit required, ¾ HP motor.

Plumbing: 20-90 psi (138-621 kPa). Machine supplied with ¼" male fitting.

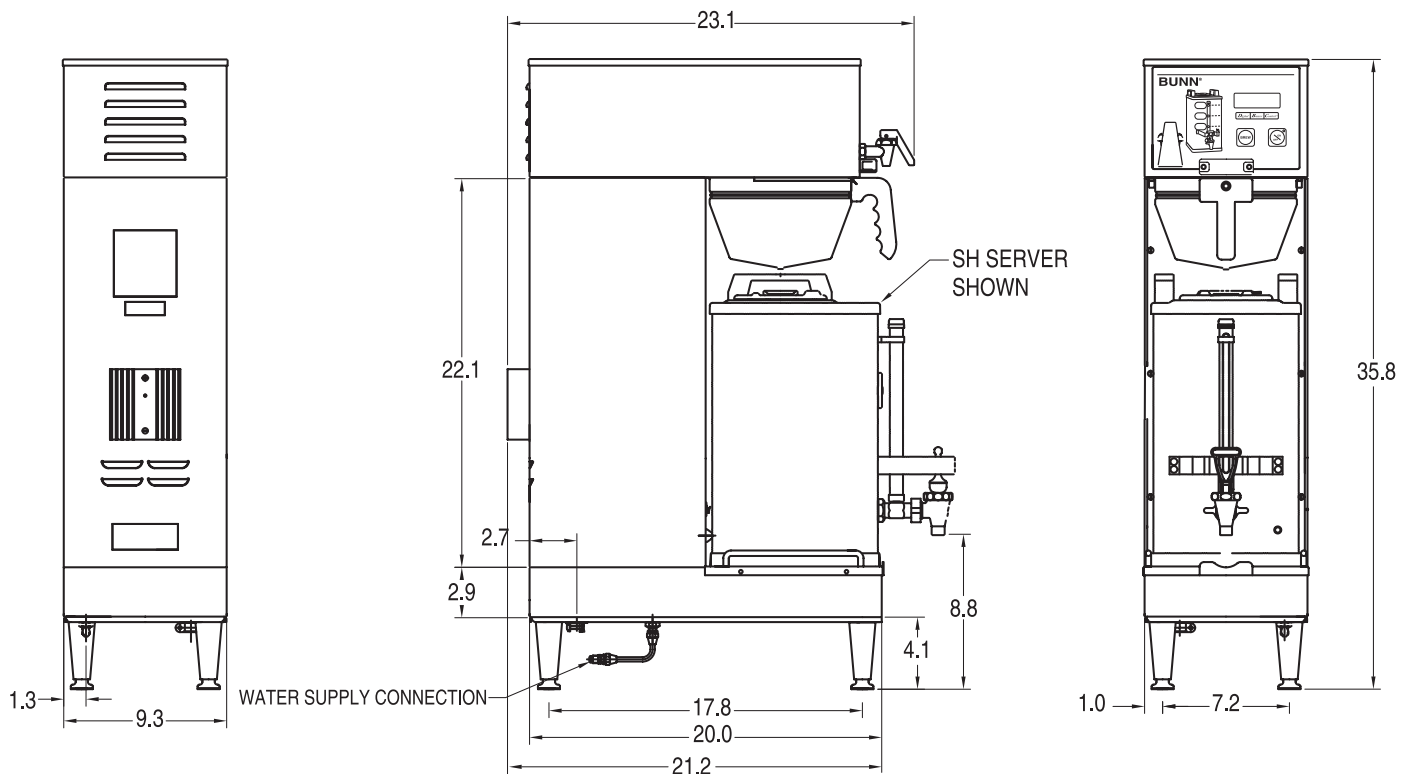

Bunn-O-Matic® Corporation - 1400 Stevenson Drive Springfield, Illinois 62703 • 800-637-8606 • 217-529-6601 • Fax 217-529-6644 • www.bunn.com

BUNN® practices continuous product research and improvement. We reserve the right to change specifications and product design without notice. Such revisions do not entitle the buyer to corresponding changes, improvements, additions or replacements for previously purchased equipment.

All dimensions shown in inches.