

BUNN®

3.0 Gallon TITAN TF SERVER

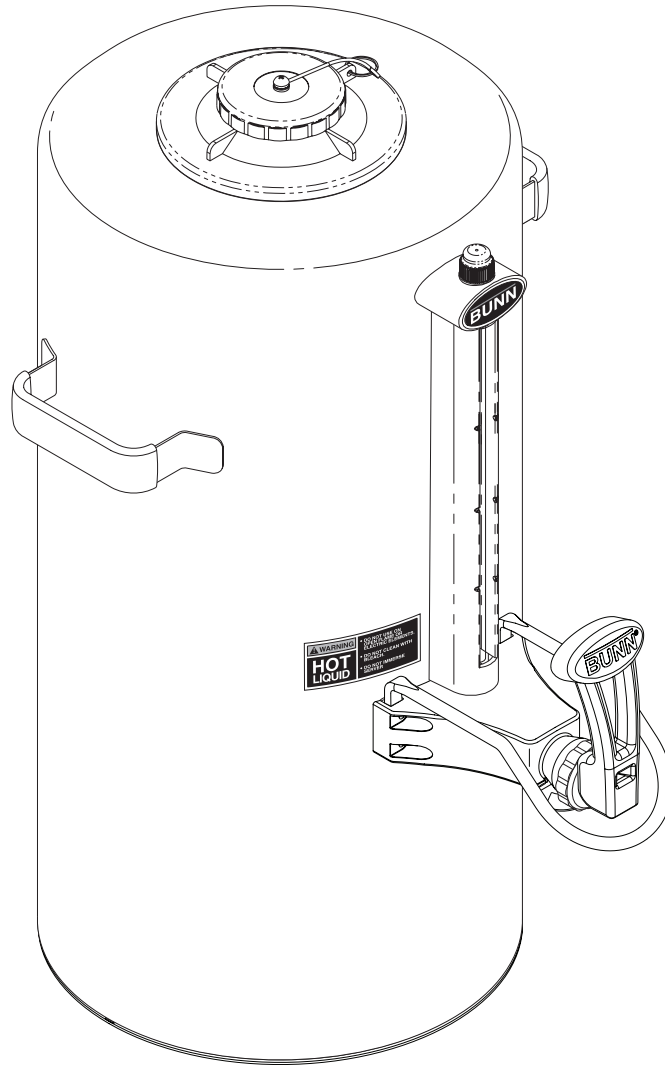

USE & CARE INFORMATION

CAUTION: CLEAN AND SANITIZE YOUR SERVER BEFORE USING. SEE NOTE 1 of DAILY CLEANING.

BUNN-O-MATIC CORPORATION

POST OFFICE BOX 3227

SPRINGFIELD, ILLINOIS 62708-3227

PHONE: (217) 529-6601 FAX: (217) 529-6644



INTRODUCTION

This server is intended for use with a BUNN® TITAN DUAL, or TITAN SINGLE coffee brewer only. When proper precautions are followed, 1.5 to 3.0 gallons of coffee may be brewed directly into the server and then transported to a remote serving location. The server must be placed on a sturdy counter or shelf.

USER NOTICES

The notices on this server should be kept in good condition. Replace unreadable or damaged labels.

#26186.0000



DAILY CLEANING

CAUTION: CLEAN AND SANITIZE YOUR SERVER DAILY

NOTE: Bunn-O-Matic recommends the 3 step method for cleaning and sanitizing the server. The 3 step method consists of hot soapy water using an approved detergent, a fresh water rinse, and an aqueous sanitizing solution using an approved **non-chlorine** sanitizer. **Do not submerge server.**

1. Run a complete brew cycle *of just hot water* into the server and let it set for a minute. Empty the server completely by opening the faucet.
2. Remove the lid, fill server with cleaning solution and thoroughly clean the inside of server.
3. Rinse server thoroughly using fresh water rinse.
4. Fully fill server with sanitizing solution for 5 minutes then drain through fully open faucet.
5. Remove the faucet handle/stem assembly by unscrewing the faucet nut just behind the faucet handle.
6. Use enclosed cleaning brush to thoroughly clean the faucet spout and connector.
7. Remove the cap, sight gauge tube and washers.
8. Use enclosed cleaning brush to thoroughly clean the fill tube of the lid assembly and sight gauge tube.
9. Disassemble the faucet/stem assembly. Thoroughly wash all faucet parts and lid in a mild detergent and water solution. Rinse the parts in hot water. Sanitize the parts for five minutes, then air dry completely.
10. Reassemble the faucet/stem assembly and attach it to the faucet.
11. Install the sight gauge tube and washers in the shroud and secure with the shroud cap.
12. Wash the entire outside surface of the server with a clean damp cloth.

SERVER

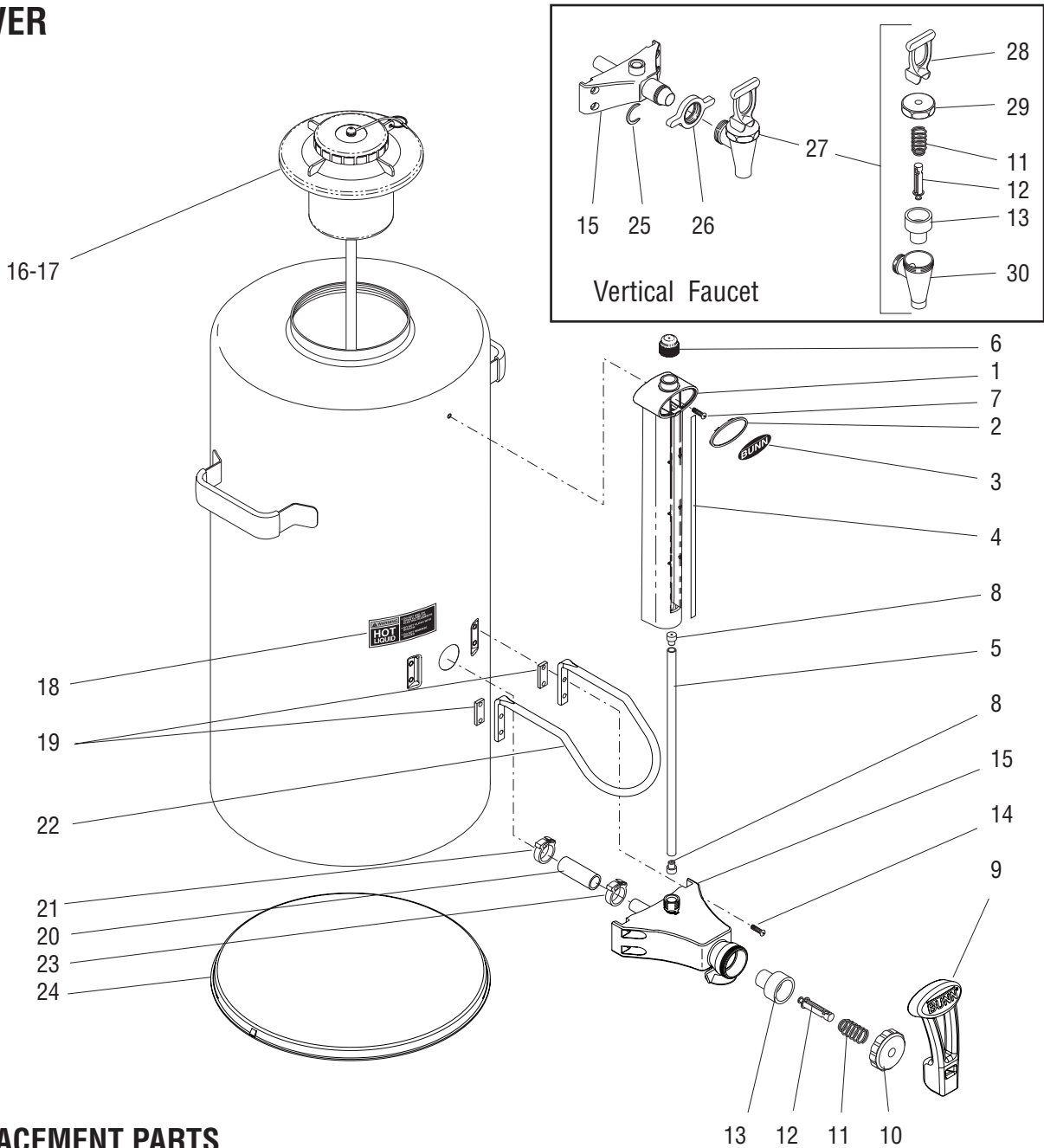

P3896

REPLACEMENT PARTS

- | | | | | | |
|-----|-------------|--|-----|-------------|--|
| 1. | 39542.1000 | Shroud, Sight Gauge (Includes Item 4) | 17. | 40106.0000 | Cap Assembly |
| 2. | 35010.0000 | Plate, Decal Mounting | 18. | 26186.0000 | Decal, Warning Hot Liquid |
| 3. | 35009.0000 | Decal, Bunn | 19. | 40097.0001 | Spacer |
| | 35009.0001 | Decal, Plain Black | 20. | 32591.1000 | Tube, Silicone .50" I.D. x 2.0"(Cut to length) |
| 4. | 35004.0002 | Backing, Sight Gauge 3.0 Gal. | 21. | 12422.0001 | Clamp, Tube .59"/.66" I.D. |
| 5. | 35005.0003 | Sight Gauge Tube 3.0 Gal. | 22. | 39543.0001 | Guard, Faucet |
| 6. | 39083.0000 | Cap, Shroud | 23. | 12422.0012 | Clamp, Tube .81"/.97" I.D. |
| 7. | 02367.0000 | Screw, Truss Head #6-32 x .62" | 24. | 40271.0000 | Cover, Bottom |
| 8. | 39143.0001 | Washer, Sight Gauge Tube | 25. | 01221.0000 | C-Ring, Faucet Shank |
| 9. | 39081.0000 | Handle, Faucet, Bunn (Horizontal Faucet) | 26. | 03093.0002 | Wing Nut, Faucet |
| 10. | 35003.0000 | Nut, Faucet Spout (Horizontal Faucet) | 27. | 26685.0000 | Faucet Assy, Bunn Handle |
| 11. | 00601.0000* | Faucet Spring | | 26685.0003 | Faucet Assy, Plain Black Handle |
| 12. | 29164.0000* | Faucet Stem | 28. | 26684.0000* | Faucet Handle, Bunn |
| 13. | 00600.0000* | Faucet Seat Cup | | 07096.0007* | Faucet Handle, Plain black |
| 14. | 35074.0000 | Screw, Hex Hd Black M4 x .7x25 | 29. | 29165.0001* | Faucet Bonnet |
| 15. | 40132.0000 | Spout, Faucet (Horizontal Faucet) | 30. | ----- * | Faucet Body (Not available. Order item 27) |
| | 41159.0000 | Shank, Faucet (Vertical Faucet) | 31. | 35301.0000 | Brush, Cleaning (Not Illustrated) |
| 16. | 39487.1000 | Lid Assembly 3.0 Gal. (Includes item 17) | | | * Component of item 27 |

BUNN-O-MATIC COMMERCIAL PRODUCT WARRANTY

Bunn-O-Matic Corp. ("BUNN") warrants equipment manufactured by it as follows:

- 1) All equipment other than as specified below: 2 years parts and 1 year labor.
- 2) Electronic circuit and/or control boards: parts and labor for 3 years.
- 3) Compressors on refrigeration equipment: 5 years parts and 1 year labor.
- 4) Grinding burrs on coffee grinding equipment to grind coffee to meet original factory screen sieve analysis: parts and labor for 3 years or 30,000 pounds of coffee, whichever comes first.

These warranty periods run from the date of installation BUNN warrants that the equipment manufactured by it will be commercially free of defects in material and workmanship existing at the time of manufacture and appearing within the applicable warranty period. This warranty does not apply to any equipment, component or part that was not manufactured by BUNN or that, in BUNN's judgment, has been affected by misuse, neglect, alteration, improper installation or operation, improper maintenance or repair, damage or casualty. This warranty is conditioned on the Buyer 1) giving BUNN prompt notice of any claim to be made under this warranty by telephone at (217) 529-6601 or by writing to Post Office Box 3227, Springfield, Illinois 62708-3227; 2) if requested by BUNN, shipping the defective equipment prepaid to an authorized BUNN service location; and 3) receiving prior authorization from BUNN that the defective equipment is under warranty.

THE FOREGOING WARRANTY IS EXCLUSIVE AND IS IN LIEU OF ANY OTHER WARRANTY, WRITTEN OR ORAL, EXPRESS OR IMPLIED, INCLUDING, BUT NOT LIMITED TO, ANY IMPLIED WARRANTY OF EITHER MERCHANTABILITY OR FITNESS FOR A PARTICULAR PURPOSE. The agents, dealers or employees of BUNN are not authorized to make modifications to this warranty or to make additional warranties that are binding on BUNN. Accordingly, statements by such individuals, whether oral or written, do not constitute warranties and should not be relied upon.

If BUNN determines in its sole discretion that the equipment does not conform to the warranty, BUNN, at its exclusive option while the equipment is under warranty, shall either 1) provide at no charge replacement parts and/or labor (during the applicable parts and labor warranty periods specified above) to repair the defective components, provided that this repair is done by a BUNN Authorized Service Representative; or 2) shall replace the equipment or refund the purchase price for the equipment.

THE BUYER'S REMEDY AGAINST BUNN FOR THE BREACH OF ANY OBLIGATION ARISING OUT OF THE SALE OF THIS EQUIPMENT, WHETHER DERIVED FROM WARRANTY OR OTHERWISE, SHALL BE LIMITED, AT BUNN'S SOLE OPTION AS SPECIFIED HEREIN, TO REPAIR, REPLACEMENT OR REFUND.

In no event shall BUNN be liable for any other damage or loss, including, but not limited to, lost profits, lost sales, loss of use of equipment, claims of Buyer's customers, cost of capital, cost of down time, cost of substitute equipment, facilities or services, or any other special, incidental or consequential damages.

BrewWISE, BrewLOGIC, BrewMETER, BrewWIZARD, Bunn Gourmet, BUNN Gourmet Ice, BUNN Pour-O-Matic, BUNN, Bunn-OMatic, Bunn-O-Matic, BUNNlink, BUNNserve, BUNNSERVE, BUNN Espresso, Cool Froth, DBC, Dr. Brew, Dual, Easy-Clear, EasyGard, Easy Pour, FlavorGard, Gourmet Ice, Gourmet Juice, High Intensity, IMIX, Infusion Series, Intellisteam, Quality Beverage Equipment Worldwide, The Mark of Quality in Beverage Equipment Worldwide, My Café, PowerLogic, Safety-Fresh, Scale-Pro, Silver Series, Single, Smart Funnel, Smart Hopper, SmartWAVE, Soft Heat, SplashGard, System III, ThermoFresh, 392, AutoPOD, AXIOM, Beverage Profit Calculator, Beverage Bar Creator, BUNNsource, Coffee At Its Best, Digital Brewer Control, Nothing Brews Like a BUNN, Pouring Profits, Pulse Wave, Signature Series, Smart Heat, Tea At Its Best, The Horizontal Red Line, Titan, Ultra, are either trademarks or registered trademarks of Bunn-O-Matic Corporation.